



Isolated Drive Transmitter

FEATURES

- 500mA Output Drive, Source or Sink
- 8 to 35V Operation
- Transmits Logic Signal Instantly
- Programmable Operating Frequency
- Under-Voltage Lockout
- Able To Pass DC Information Across Transformer
- Up To 600kHz Operation

DESCRIPTION

The UC1724 family of Isolated Drive Transmitters, along with the UC1725 Isolated Drivers, provide a unique solution to driving isolated power MOSFET gates. They are particularly suited to drive the high-side devices on a high-voltage H-bridge. The UC1724 devices transmit drive logic, and drive power, to the isolated gate circuit using a low cost pulse transformer.

This drive system utilizes a duty-cycle modulation technique that gives instantaneous response to the drive control transistions, and reliably passes steady-state, or DC, conditions. High frequency operation, up to 600kHz, allows the cost and size of the coupling transformer to be minimized.

These devices will operate over an 8 to 35 Volt supply range. The dual high current totem pole outputs are disabled by an under-voltage lockout circuit to prevent spurious responses during startup or low voltage conditions.

These devices are available in 8-pin plastic or ceramic dual-inline packages, as well as surface mount packages.

BLOCK DIAGRAM

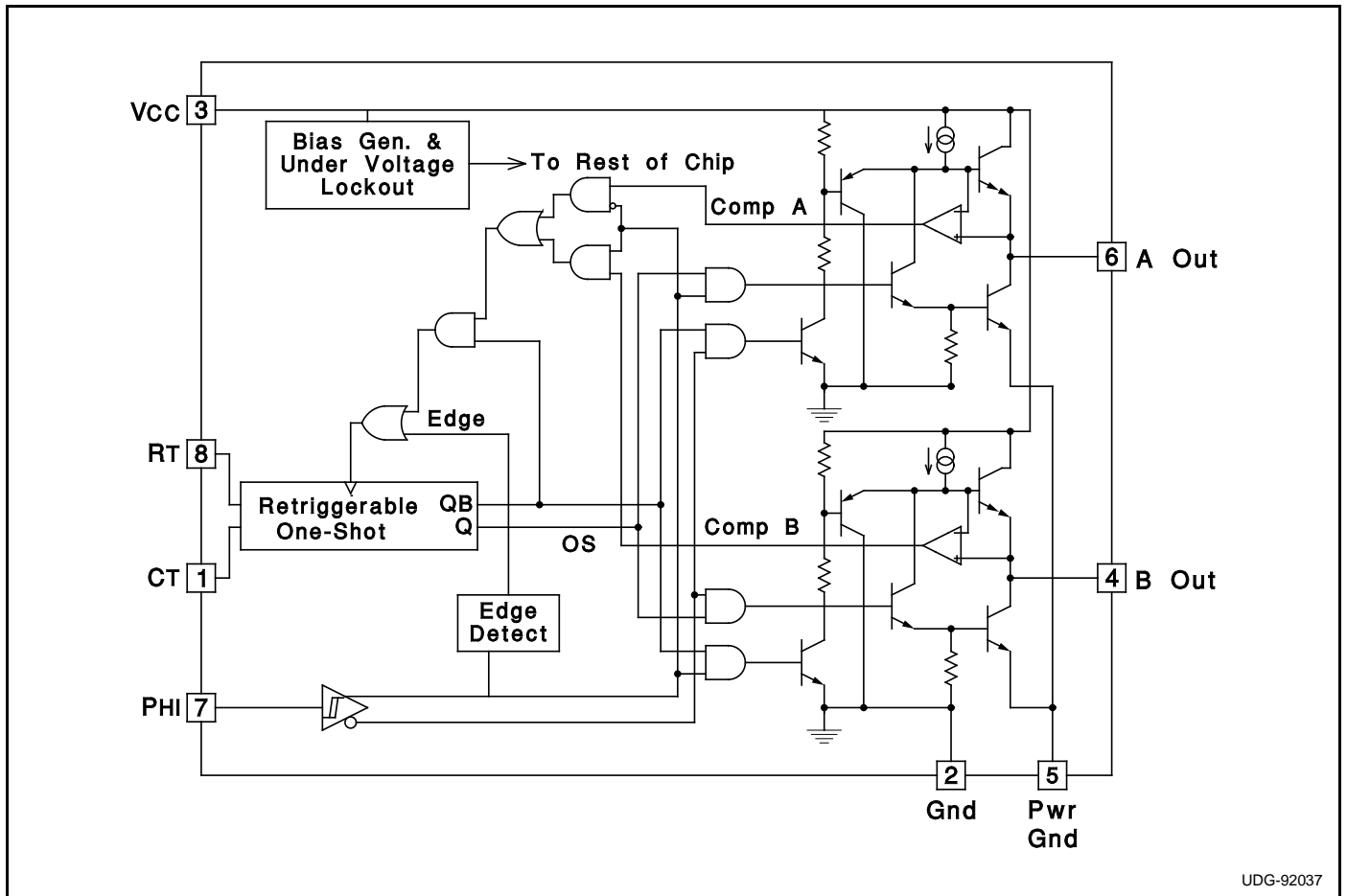

UDG-92037

Note: Pin numbers refer to DIL-8 packages.

ABSOLUTE MAXIMUM RATINGS

Supply Voltage V_{IN} 40V
 Source/Sink Current (Pulsed) 1A
 Source/Sink Current (Continuous) 0.5A
 Output Voltage (Pins 4, 6) -0.3 to $(V_{IN} + 0.3)V$
 Φ_{HI} , R_T , and C_T inputs (Pins 1, 7, and 8) -0.3 to 6V
 Operating Junction Temperature (Note 2) 150°C
 Storage Temperature Range -65°C to 150°C
 Lead Temperature (Soldering, 10 Seconds) 300°C

Note 1: All voltages are with respect to GND (Pin 2); all currents are positive into, negative out of part.
 Note 2: Consult *Unitorde Integrated Circuit Databook* for thermal limitations and considerations of package.
 Note 3: Pin numbers refer to DIL-8 packages.

CONNECTION DIAGRAMS

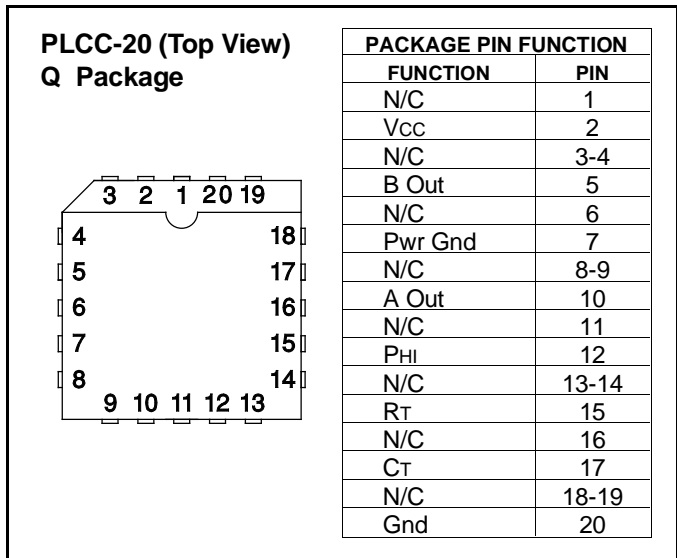
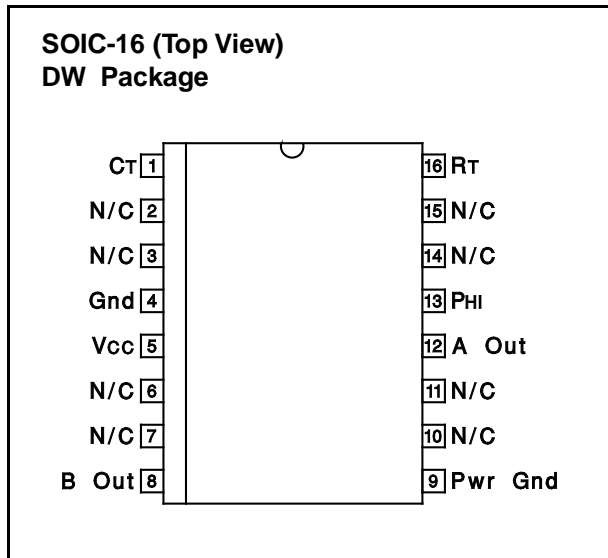
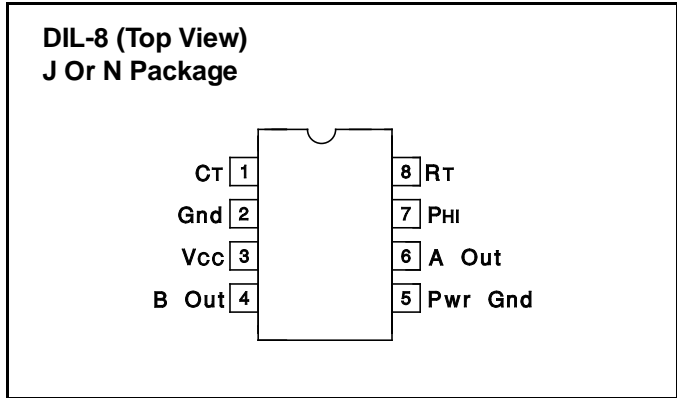

RECOMMENDED OPERATION CONDITIONS (Note 4)

Input Voltage +9V to +35V
 Sink/Source Load Current (each output) 0 to 500mA
 Timing Resistor 2k Ω to 10k Ω
 Timing Capacitor 300pF to 3nF
 Operating Temperature Range (UC1724) -55°C < T_A < 125°C
 Operating Temperature Range (UC3724) 0°C < T_A < 70°C

Note 4: Range over which the device is functional and parameter limits are guaranteed.

ELECTRICAL CHARACTERISTICS: Unless otherwise stated, $V_{CC} = 20V$, $R_T = 4.3k\Omega$, $C_T = 1000pF$, no load on any output and these specifications apply for: -55°C < T_A < 125°C for the UC1724, -25°C < T_A < 85°C for the UC2724, and 0°C < T_A < 70°C for the UC3724. $T_A = T_J$.

PARAMETER	TEST CONDITIONS	MIN	TYP	MAX	UNITS
Under-Voltage Lockout					
Start-Up Threshold	V_{IN} Rising		7.75	9.5	V
Threshold Hysteresis		0.4	1.0	1.5	V
Retriggerable One-Shot					
Initial Accuracy	$T_J = 25^\circ C$	1.54	1.9	2.25	μs
Temperature Stability	Over Operating T_J	1.0		2.9	μs
Voltage Stability	$V_{IN} = 10$ to 35V		0.2	0.5	%/V
Operating Frequency	$L_{LOAD} = 1.4mH$	100	150	200	kHz
Minimum Pulse Width	$R_T = 2k \ C_T = 300pF$	100	500	1200	ns
Operating Frequency	$R_T = 2k \ C_T = 300pF \ L_{LOAD} = 1.4mH$	500	750	1100	kHz

ELECTRICAL CHARACTERISTICS (cont.)

Unless otherwise stated, $V_{CC} = 20V$, $R_T = 4.3k\Omega$, $C_T = 1000pF$, no load on any output and these specifications apply for: $-55^{\circ}C < T_A < 125^{\circ}C$ for the UC1724, $-25^{\circ}C < T_A < 85^{\circ}C$ for the UC2724, and $0^{\circ}C < T_A < 70^{\circ}C$ for the UC3724. $T_A = T_J$.

PARAMETER	TEST CONDITIONS	MIN	TYP	MAX	UNITS
Phi Input (Control Input)					
HIGH Input Voltage		2.0			V
LOW Input Voltage				0.8	V
HIGH Input Current	$V_{IH} = +2.4V$	-220	-130		mA
LOW Input Current	$V_{IL} = +0.4V$	-600	-300		μA
Delay to One-Shot				350	ns
Delay to Output				250	ns
Output Drivers					
Output Low Level	$I_{SINK} = 50mA$		0.3	0.4	V
	$I_{SINK} = 250mA$		0.5	2.1	V
Output High Level (Volts Below V_{CC})	$I_{SOURCE} = 50 mA$		1.5	2.1	V
	$I_{SOURCE} = 250 mA$		1.7	2.5	V
Rise/Fall Time	No load		30	90	ns
Total Supply Current					
Supply Current	$C_T = 1.4V$		15	30	mA

Typical Application

